

#12/12/12 Stacked Valve – DC Unit Layout

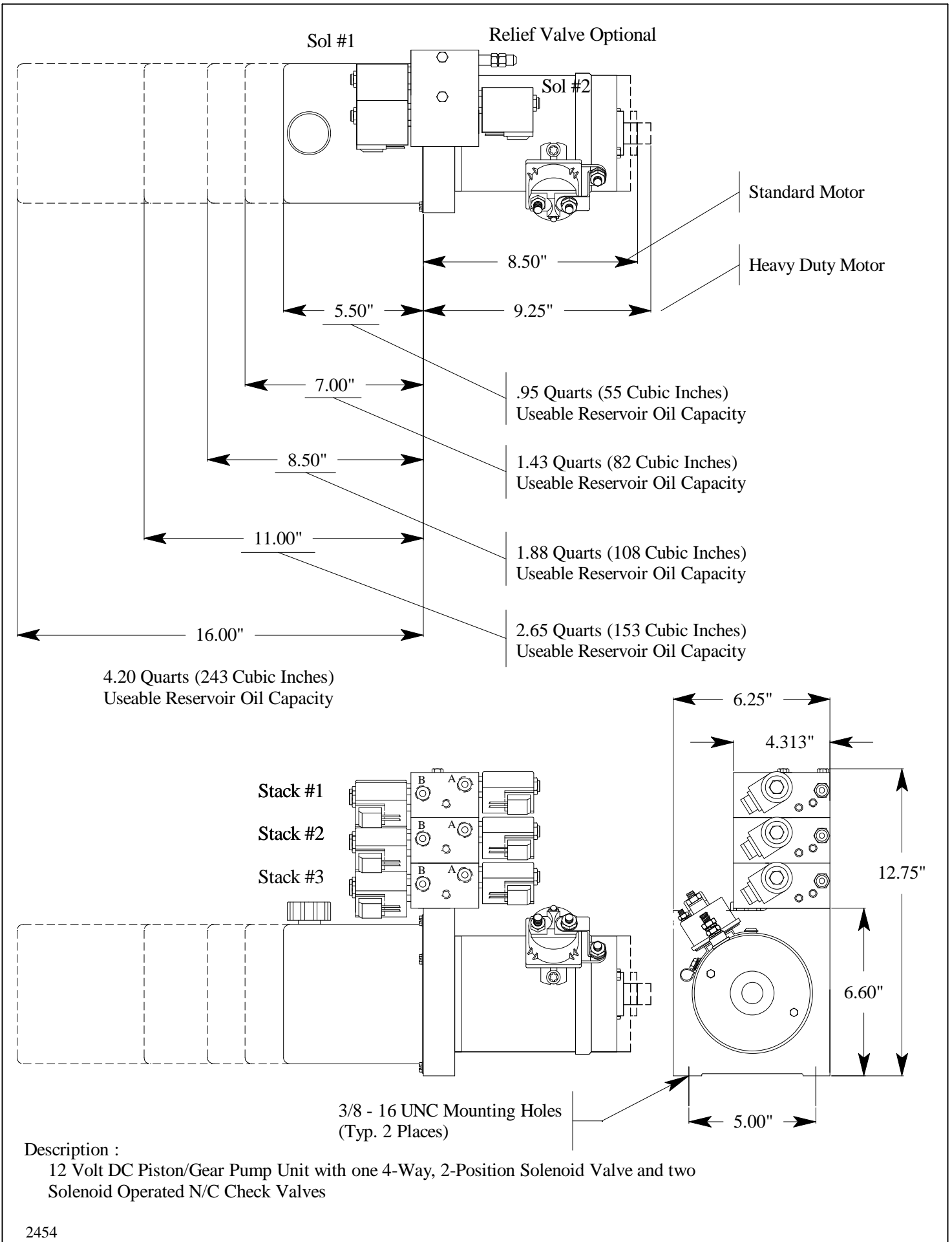

#12/12/12 Stacked Valve – Schematic

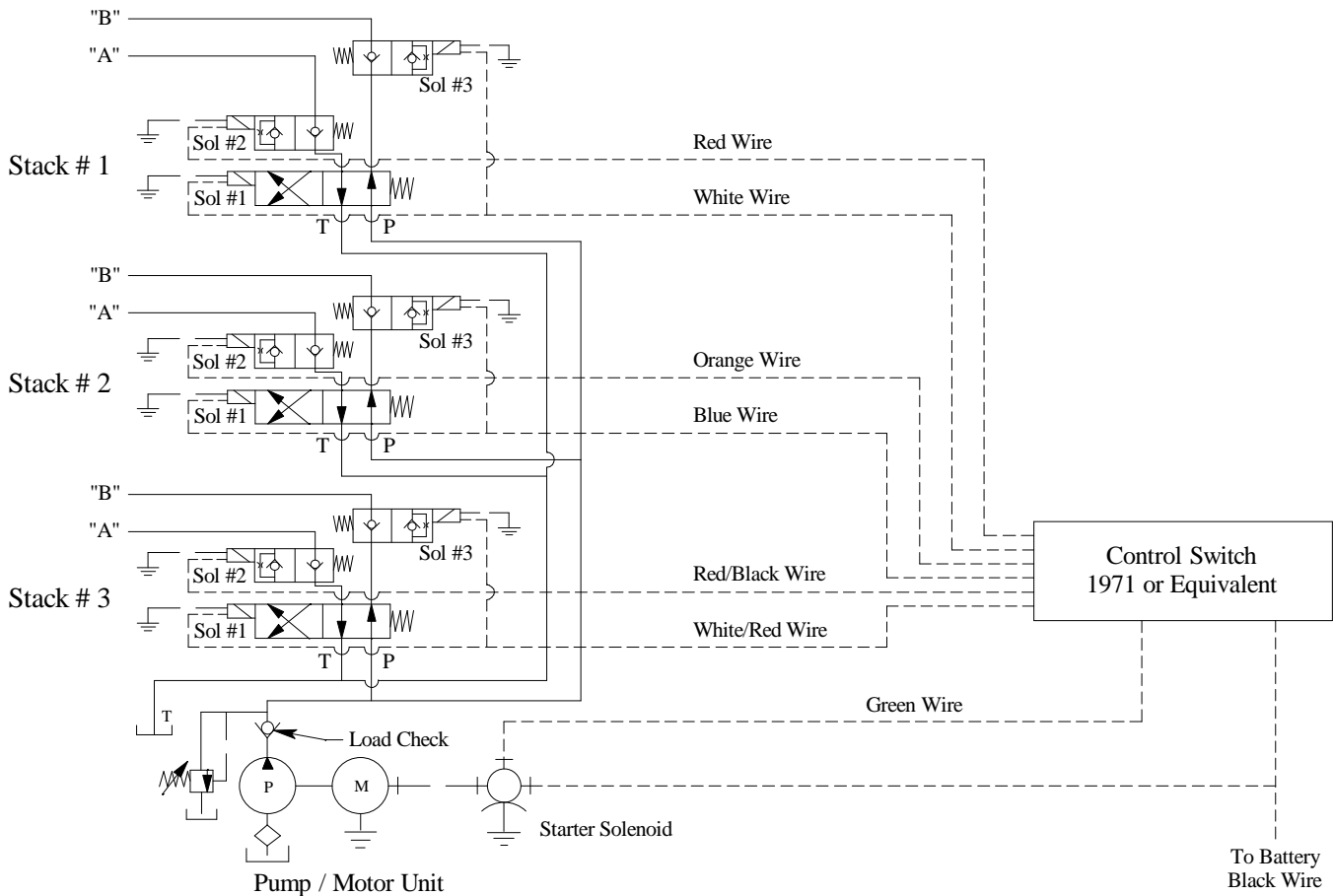

System Function (Each Valve Stack)

Energizing Power unit, Sol # 1, and Sol # 3, oil is directed to Port "A" and oil from Port "B" is directed back to tank ("T" Port).

Energizing Power unit and Sol # 2, oil is directed to Port "B" and oil from Port "A" is directed back to tank ("T" Port).

Application (Each Valve Stack)

1. Power up / Power Down
2. Power extend / Power retract

Note :

When either one of the #12 valves are actuated, both hoses of the other valve will pressurize. This is normal in this design.

Valve Characteristics (Each Valve Stack)

1. Uses one 4-way, 2-position spool type cartridge valve and two 2-way NC P.O. poppet type cartridge valves, solenoid operated.
2. Aluminum manifold block machined for one 4-way, 2-position cartridge valve, two 2-way cartridge valves and with two 3/8" NPT Ports.
3. On stack #1, "B" port relief is plugged. In applications where a low pressure relief is required, a #24 valve is recommended.

Limitations (Each Valve Stack)

1. When lifting and/or holding a load, use port "A".
2. If valves are used in an application in which a cylinder is to be lowered with a load on it (overriding load), it should be noted that pressure surges can occur in the load holding hose on the valve that is being operated.
3. Horizontal Mounting.